



OVERVIEW

The DM6.0 is a dynamic moving coil microphone designed to handle a wide variety of vocal and instrument applications for both live sound and recording. Characteristics of the DM6.0, such as a tight super-cardioid pickup pattern with a frequency response of 50Hz-16 KHz, slight bass proximity and mid range presence result in a warm and natural sounding response for every application. The DM6.0 is engineered to handle very high source levels without distortion and provides over 26dB of off axis feedback rejection.

Low impedance and balanced output allow interference free performance. The DM6.0 is built solidly with a cast zinc alloy body, steel mesh grille ball and internal pop screen.

SPECIFICATIONS

- Transducer Type:** Dynamic
- Frequency Response:** 50Hz - 16 KHz
- Polar Pattern:** Super-cardioid
- Output Impedance:** 12ohms
- Sensitivity:** - 53dB (0dB=1V/Pa)
- Off-axis rejection:** >26dB at 125°
- Maximum SPL:** >136dB
- Cable/Connector:** 3 pin gold plated male XLR
- Polarity:** Positive voltage on pin 2 relative to pin 3 of output XLR connector
- Housing:** Zinc alloy
- Weight:** 334 gram



APPLICATIONS

- + Live Stage**
Clubs, Houses of Worship, Corporate Presentations, Karaoke
- + Instruments**
Electric guitar amplifiers, drums, horns, percussion
- + Home Studio**
All vocal and instrument applications

FEATURES

- + A lower impedance 12 ohm coil heightens sensitivity for crystal clear reproduction of vocals and instruments**
- + Incredibly accurate super-cardioid pattern means improved rejection of off axis sound sources for improved isolation and reduced feedback**
- + Capsule features Neodymium magnet structure for low self noise and high sensitivity**
- + Wide frequency response suitable for both vocal and instrumental applications**

POLAR CHARTS

The frequency response curve shown above (measuring response at +3dB) and polar pattern correspond to typical production run specifications for this microphone.

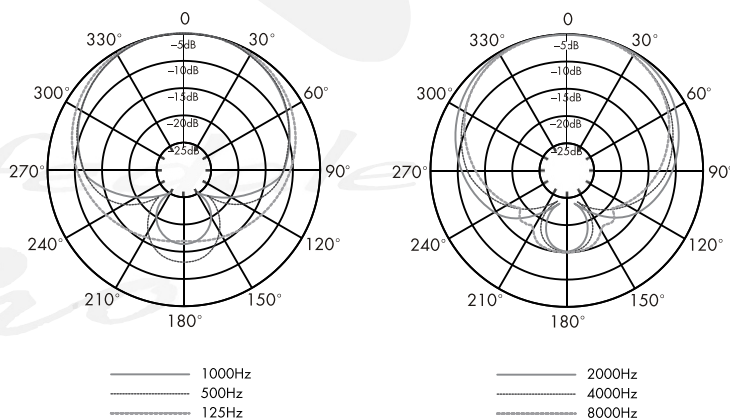

Microphone Frequency Response 0dB=2.3mV/Pa

